

# VERTILINE

## ***Rack Mount Power Supplies***

### ***Installation Guide***

#### ***Models Include:***

##### ***Vertiline3D***

- 12VDC @ 8 amp
- Eight (8) PTC protected outputs

##### ***Vertiline6D***

- 24VDC @ 8 amp
- Eight (8) PTC protected outputs



Rev. 090710



More than just power.™

## Overview:

Altronix Vertiline Rack Mount Power Supplies provide eight (8) filtered and electronically regulated power outputs in a space saving 1U EIA 19" rack mount chassis. The units are available with either 12VDC or 24VDC power outputs. Vertiline Rack Mount Power Supplies are also available in sixteen (16) outputs.

## Specifications:

### Agency Listing:

- CE European Conformity.

### Input:

- 115VAC 60 Hz.

### Output:

#### Vertiline3D:

- Eight (8) PTC protected 12VDC outputs rated @ 8 amp total current max. (1.0 amp per device, 2.5 amp max.).

#### Vertiline6D:

- Eight (8) PTC protected 24VDC outputs rated @ 8 amp total current max. (1.0 amp per device, 2.5 amp max.).
- Filtered and electronically regulated outputs.

### Features:

- Eight (8) power LED indicators.
- Illuminated master power disconnect circuit breaker with manual reset.
- IEC 320 - 3-wire grounded line cord (detachable).
- Removable terminal blocks with locking screw flange.

### Mechanical:

- Units can be rack, wall or shelf mounted.
- Modular 1U standard EIA 19" rack mount chassis.
- Enclosure Dimensions (H x W x D approx.): 1.625" x 19.125" x 8.5" (41.3mm x 486mm x 216mm).

## Eight (8) Output Rack Mount Configuration Reference Chart:

Altronix Model Number	Output Voltage	Total Output Current (Power)	Number of Outputs	PTC Output Protection	Current (max. per output)	115VAC 60Hz Input Current
Vertiline3D	12VDC	8 amp	8	PTC	2.5 amp	1.5 amp
Vertiline6D	24VDC	8 amp	8	PTC	2.5 amp	3 amp

**WARNING: To reduce the risk of fire or electric shock, do not expose the unit to rain or moisture. This installation should be made by qualified service personnel and should conform to all local codes and in accordance with the National Electrical Code.**

## Installation Instructions:

1. Attach mounting brackets to Vertiline unit for desired rack or wall mount installation (Figs. 3-4, pg. 7). Affix rubber pads to Vertiline for shelf installation (Fig. 5, pg. 7).
2. Secure the unit into rack, mount unit to wall or place unit on a shelf as desired (unit should be spaced at least 3" from any video monitors). When installing the unit in a rack, allow for one half U spacing above the unit for ventilation.
3. Insert and secure removable terminal blocks to unit (Fig. 1e, pg. 4).
4. Plug the grounded AC line cord (included) into the IEC 320 connector of the Vertiline unit (Fig. 1d, pg. 4). Insert the plug end of the line cord into a grounded AC, receptacle.
5. Set illuminated master power disconnect circuit breaker to the (ON) position (Fig. 1c, pg. 4).
6. Measure output voltage before connecting devices. This helps avoiding potential damage.
7. Set illuminated master power disconnect circuit breaker to the (OFF) position (Fig. 1c, pg. 4).
8. Connect the power output of terminals marked [+ 1 - ] to the power input of device (Fig. 1b, pg. 4). Repeat this step for each additional device (Outputs 2-8).
9. Upon completion of wiring, set illuminated master power disconnect circuit breaker to the ON (RESET) position (Fig. 1c, pg. 4).

10. The power LEDs on the faceplate for Outputs 1-8 will illuminate when AC power is present (*Fig. 1a, pg. 4*).

**Note:** If any of the power LEDs are not illuminated the cause may be due to the following:

- a. AC mains fail.
- b. Illuminated master power disconnect circuit breaker is OFF or tripped.
- c. One (1) or more power output PTCs are tripped due to a short circuit or overload condition.

To reset the PTC:

1. Set illuminated master power disconnect circuit breaker to the (OFF) position (*Fig. 1c, pg. 4*).
2. Eliminate the trouble condition (short circuit or overload).
3. Allow 1 minute for PTC to cool off (reset).
4. Set illuminated master power disconnect circuit breaker to the (ON) position (*Fig. 1c, pg. 4*).
5. All power LEDs will illuminate indicating power has been restored to all outputs (*Fig. 1a, pg. 4*).

Fig. 1

*Vertiline3D and Vertiline6D (front)*

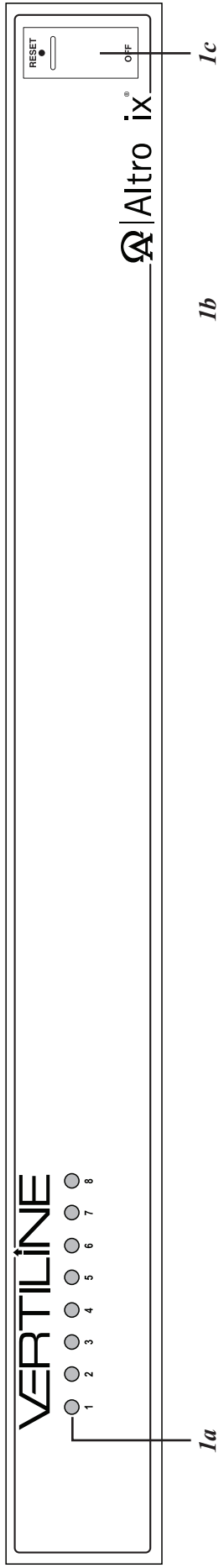

1a

1b

1c

*Vertiline3D and Vertiline6D (rear)*

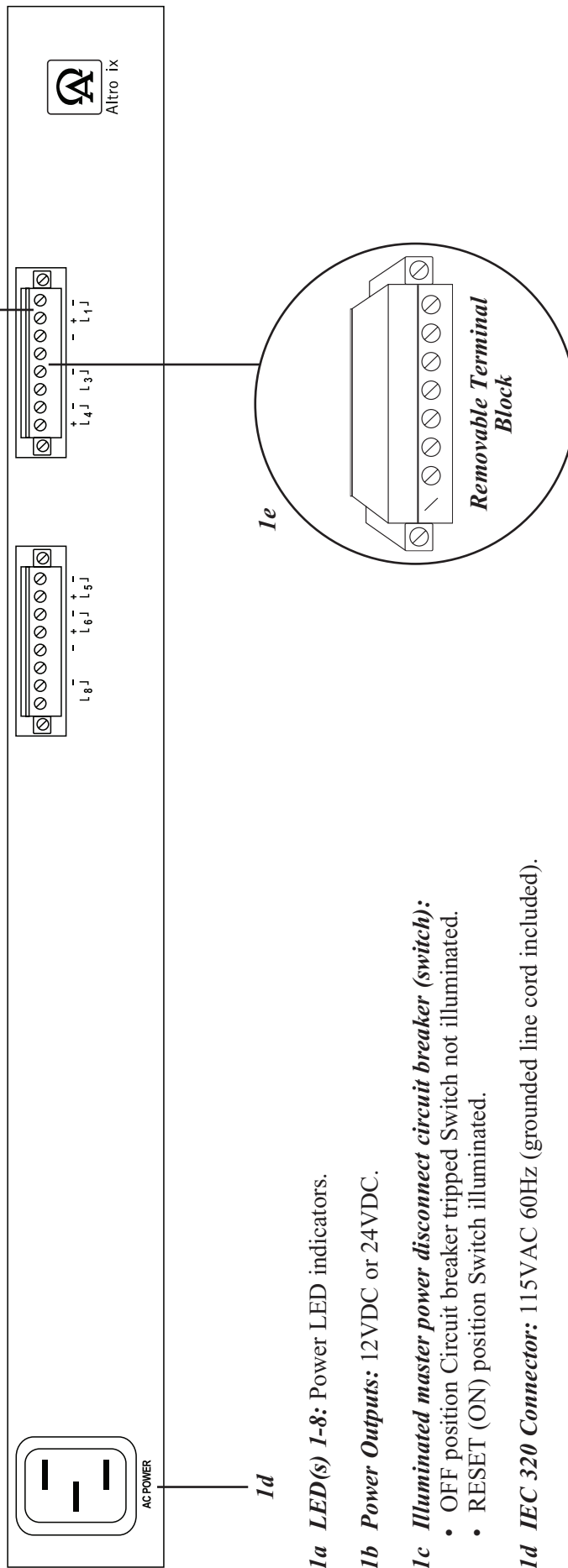

1d

1e

**1a LED(s) 1-8:** Power LED indicators.

**1b Power Outputs:** 12VDC or 24VDC.

**1c Illuminated master power disconnect circuit breaker (switch):**

- OFF position Circuit breaker tripped Switch not illuminated.
- RESET (ON) position Switch illuminated.

**1d IEC 320 Connector:** 115VAC 60Hz (grounded line cord included).

**1e Removable Terminal Block.**

**Typical Application Drawing:**

Fig. 2

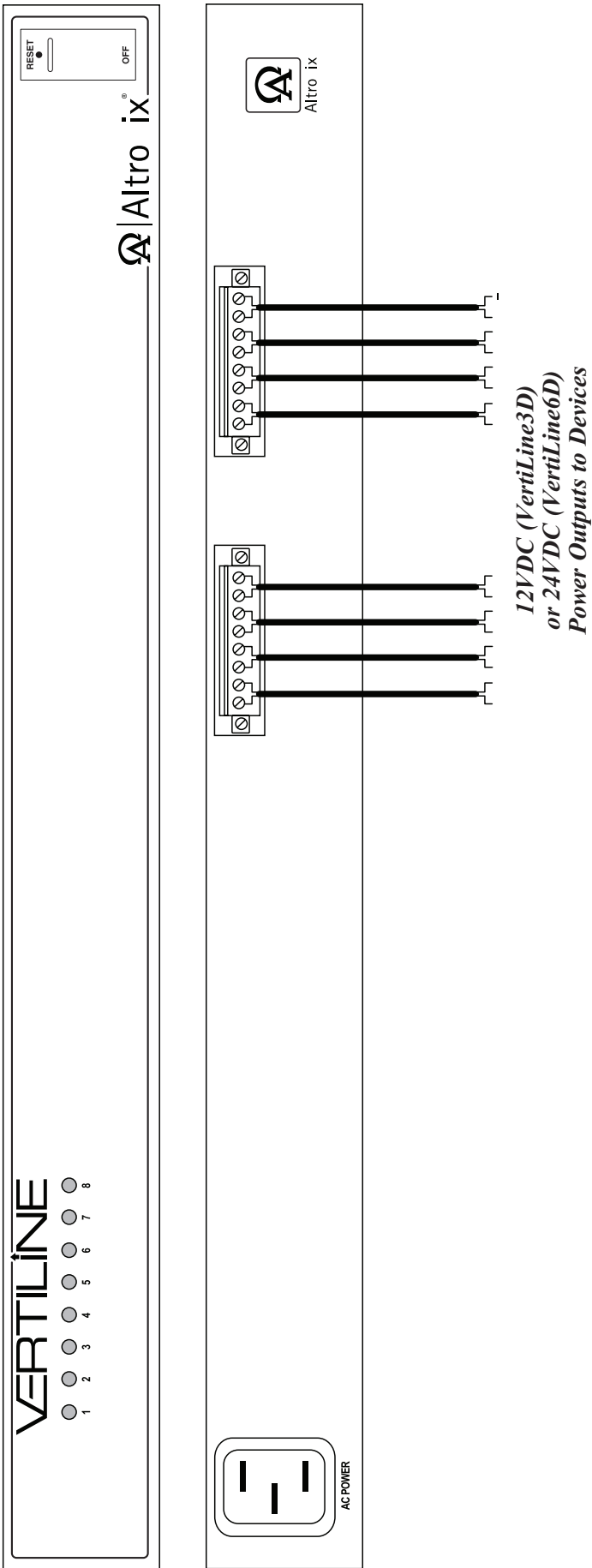



The lightning flash with arrow head symbol within an equilateral triangle is intended to alert the user to the presence of an insulated **DANGEROUS VOLTAGE** within the product's enclosure that may be of sufficient magnitude to constitute an electric shock.



The exclamation point within an equilateral triangle is intended to alert the user to the presence of important operating and maintenance (servicing) instructions in the literature accompanying the appliance.



**CAUTION**  
RISK OF ELECTRIC SHOCK  
DO NOT OPEN



**CAUTION:** To reduce the risk of electric shock do not open enclosure. There are no user serviceable parts inside. Refer servicing to qualified service personnel.

**1U EIA 19" Rack Mount Chassis Mechanical Drawing and Dimensions (H x W x D):**  
1.625" x 19.125" x 8.5" (41.3mm x 486mm x 216mm)

REAR



17.625"  
447.7mm

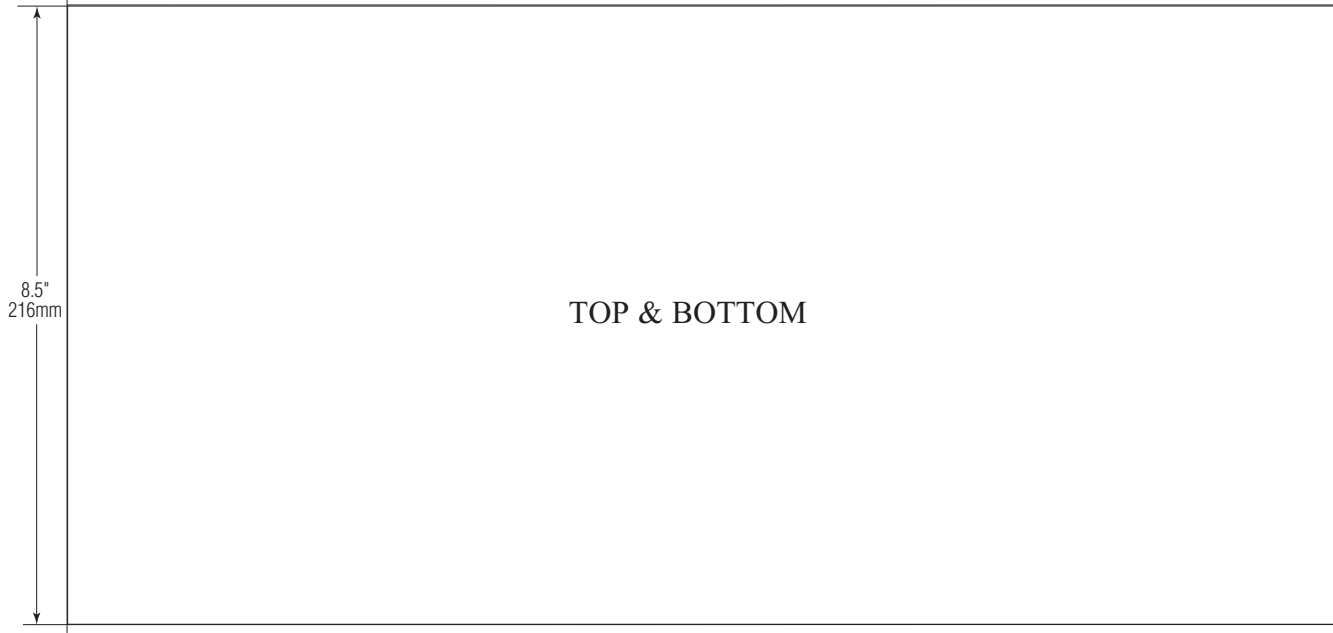

FRONT

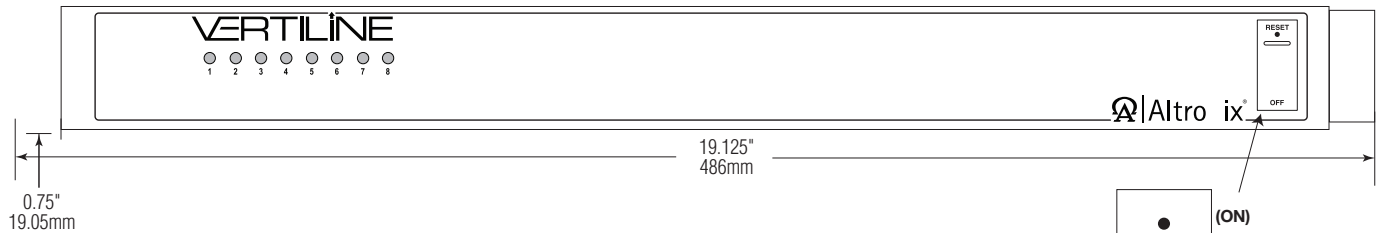

Illuminated master power disconnect circuit breaker:

- OFF position - Switch not illuminated. Outputs not powered.
- RESET (ON) position - Switch illuminated. Outputs powered.
- Circuit breaker tripped - Switch not illuminated. Power LEDs on faceplate are not illuminated. Outputs not powered.
- To reset circuit breaker, set power switch to the ON (RESET) position.

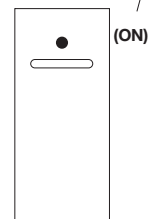

## Chassis Mounting Options:

### Rack Mount Installation

1. Remove factory installed screws from both sides of rack chassis (Fig. 3a).
2. Attach mounting brackets (A) on the left and right side of rack chassis using the two (2) flat head screws (B) (included) (Fig. 3b).
3. Install unit into desired EIA 19" rack position and secure with mounting screws (not included) (Fig. 3c).

Fig. 3

Fig. 3a

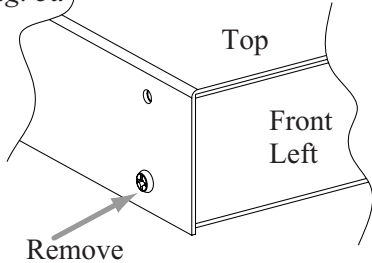

Fig. 3b

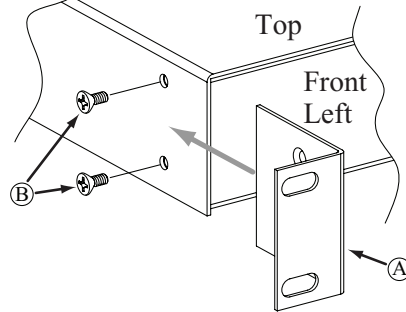
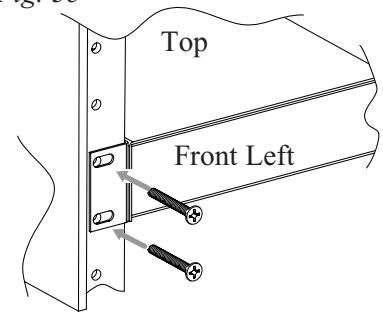

Fig. 3c



### Wall Mount Installation

1. Attach mounting brackets (A) on the left and right side of rack chassis using two (2) flat head screws (B) (included) (Fig. 4a).
  2. Secure unit to wall with appropriate screws/hardware (not included) (Fig. 4b).
- Caution:** It is necessary to make sure mounting screws are securely fastened to a beam when installing.

Fig. 4

Fig. 4a

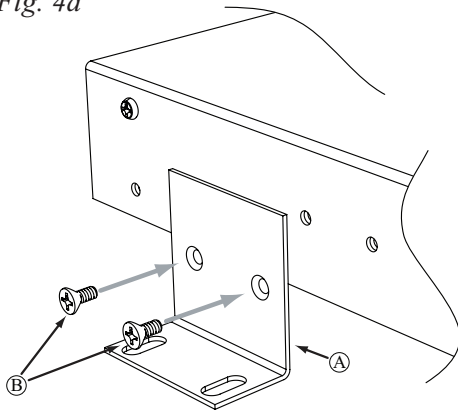
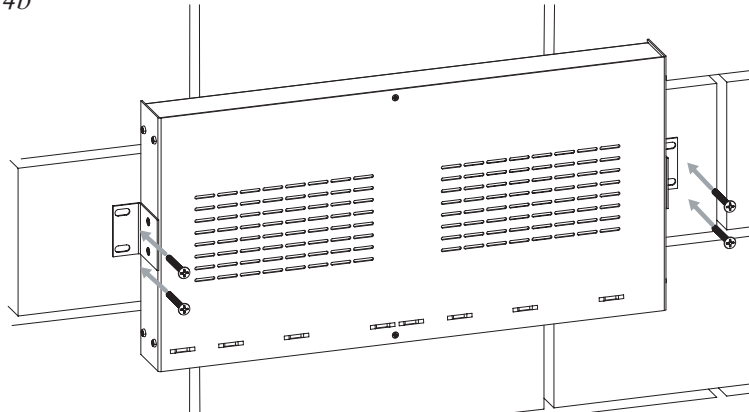

Fig. 4b



### Shelf Installation

1. Position and affix rubber pads (C) (included) at each corner on the bottom of the unit (Fig. 5).
2. Place unit in desired location.

Fig. 5

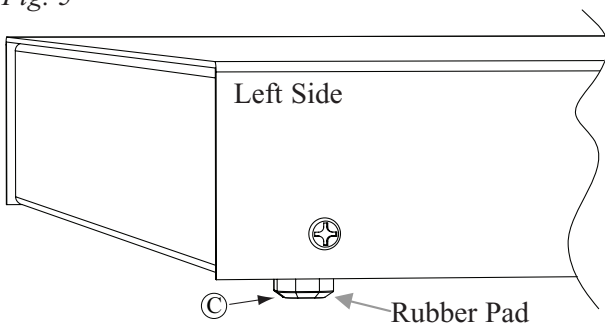

#### Hardware (Included):

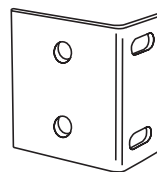

Ⓐ Two (2) mounting brackets



Ⓑ Six (6) flat head screws for mounting brackets.



Ⓒ Four (4) rubber pads.

## **Notes:**

Altronix is not responsible for any typographical errors.

140 58th Street, Brooklyn, New York 11220 USA, 718-567-8181, fax: 718-567-9056  
web site: [www.altronix.com](http://www.altronix.com), e-mail: [info@altronix.com](mailto:info@altronix.com). Lifetime Warranty, Made in U.S.A.  
IIVertiline3DSeries

H040

- 8 -



**MEMBER**

*Vertiline3D/VertiLine6D*