

AXIS Q87 Bispectral PTZ Network Camera Series

AXIS Q8741-E Bispectral PTZ Network Camera

AXIS Q8741-LE Bispectral PTZ Network Camera

AXIS Q8742-E Bispectral PTZ Network Camera

AXIS Q8742-LE Bispectral PTZ Network Camera

User Manual

AXIS Q87 Bispectral PTZ Network Camera Series

Table of Contents

Solution overview	3
Product overview	4
How to access the product	7
How to access the product from a browser	7
About secure passwords	7
Setup	8
About the product's built-in help	8
About events	8
How to set up the camera for daily cleaning of the visual window	9
Image quality	10
PTZ (Pan Tilt Zoom)	12
Streaming and storage	12
About applications	13
Install an SD card (pre-mounted)	13
Troubleshooting	15
Reset to factory default settings	15
How to check the current firmware	16
How to upgrade the firmware	16
Technical issues, clues and solutions	16
Performance considerations	17
Specifications	19
SD card slot	19
Connectors	19

AXIS Q87 Bispectral PTZ Network Camera Series

Solution overview

Solution overview

The AXIS Q87 Bispectral PTZ Network Camera is intended for mission-critical surveillance that demands 24-hour monitoring of restricted areas, such as airports (1).

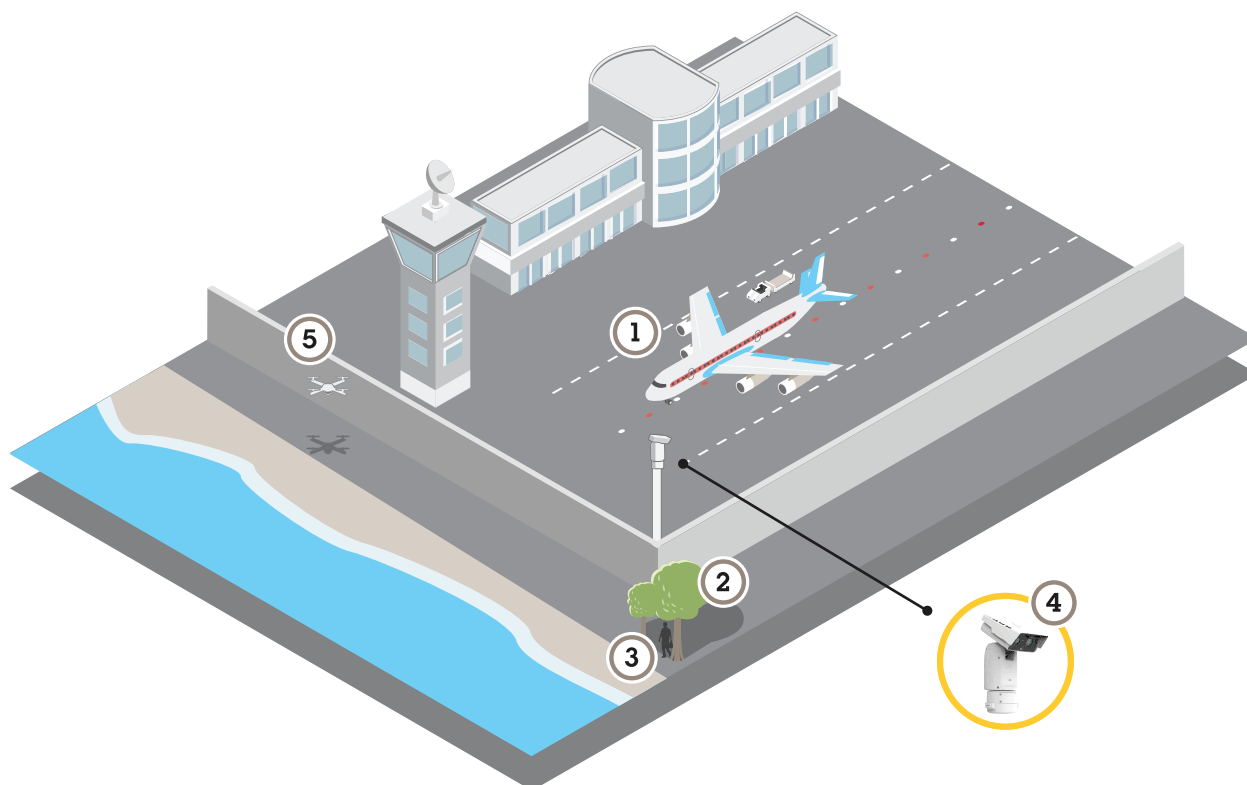

In difficult lighting conditions (2), the thermal camera can detect objects (3) that the visual camera cannot. This allows you to set up an event, using motion detection on the thermal camera, to zoom in and record with the visual camera. To find out more, go to [page 8](#).

The camera (4) is often installed in inaccessible locations. The built-in wiper and optional washer allows you to remove for instance sea salt, from the front window without physically accessing it. To find out more, go to [How to set up the camera for daily cleaning of the visual window on page 9](#).

The wide tilt range allows you to, for example, detect various flying objects (5).

AXIS Q87 Bispectral PTZ Network Camera Series

Product overview

Product overview

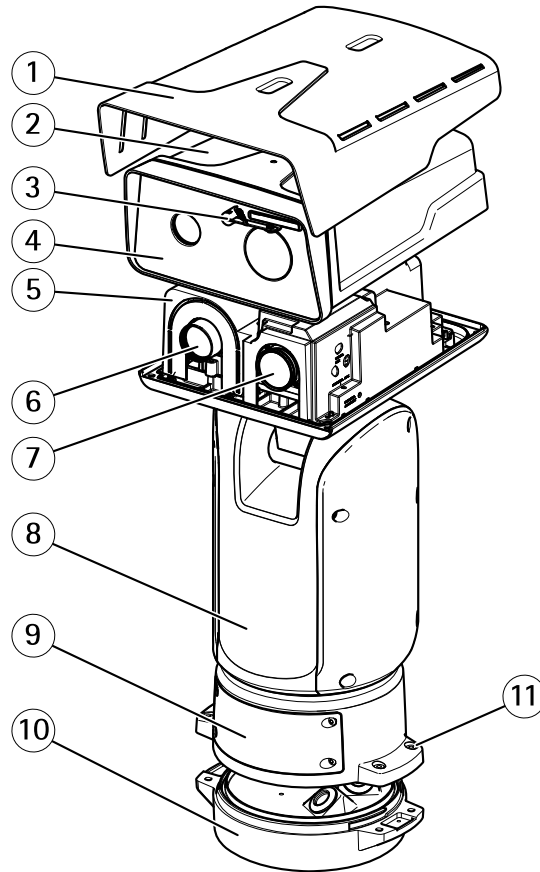

- 1 Weathershield
- 2 Top cover
- 3 Wiper
- 4 Front with protective foil
- 5 Inner cover
- 6 Thermal lens
- 7 Visual lens
- 8 Positioning unit
- 9 Lid
- 10 Base unit
- 11 Base unit screws

AXIS Q87 Bispectral PTZ Network Camera Series

Product overview

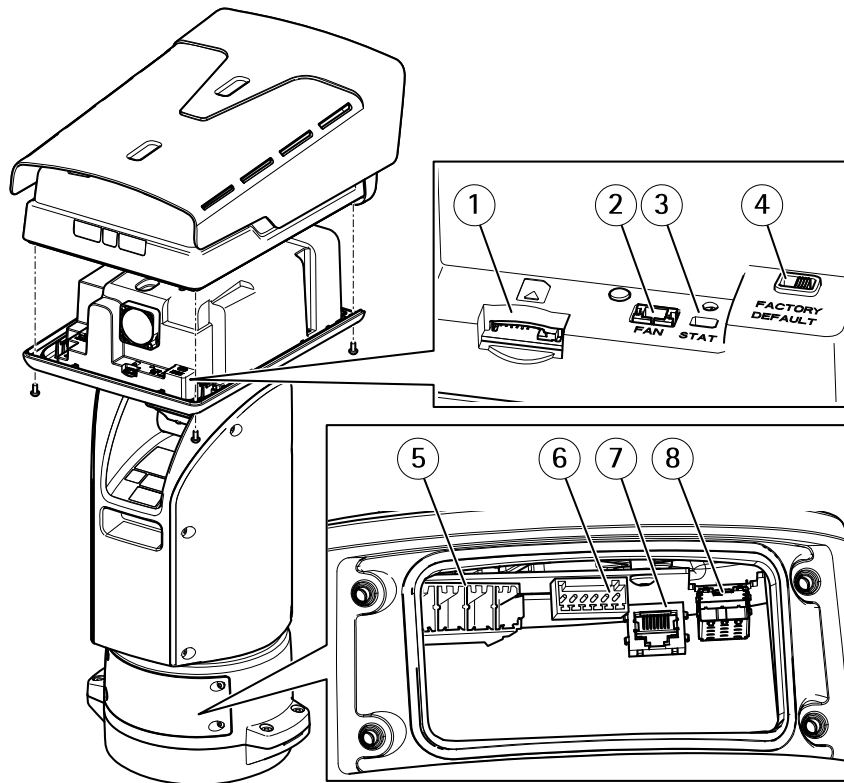

- 1 SD card slot (microSDHC UHS-I/microSDXC UHS-I) (card included)
- 2 Fan connector
- 3 Status LED
- 4 Factory default switch
- 5 Input power connector
- 6 I/O connector
- 7 RJ45 connector
- 8 SFP slot for SFP module (SFP module not included)

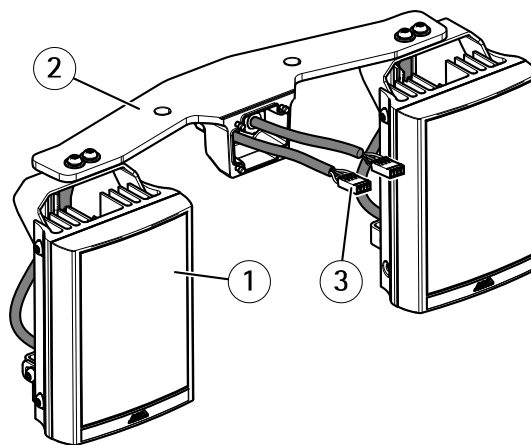

- 1 Illuminator (x2)
- 2 Illuminator bracket
- 3 Illuminator connector (x2)

AXIS Q87 Bispectral PTZ Network Camera Series

Product overview

Note

The illuminator kit is included for:

AXIS Q8741-LE Bispectral PTZ Network Camera

AXIS Q8742-LE Bispectral PTZ Network Camera

AXIS Q87 Bispectral PTZ Network Camera Series

How to access the product

How to access the product

AXIS IP Utility and AXIS Device Manager are recommended methods for finding Axis products on the network and assigning them IP addresses in Windows®. Both applications are free and can be downloaded from axis.com/support

The product can be used with the following browsers:

- Windows®: Chrome™ (recommended), Firefox®, Edge®, or Opera®
- OS X®: Chrome™ (recommended) or Safari®
- Other operating systems: Chrome™ or Firefox®.

If you need more information about recommended browsers, go to axis.com/browser-support

How to access the product from a browser

1. Start a web browser.
2. Enter the IP address or host name of the Axis product in the browser's address field.
3. Enter your username and password. If this is the first time the product is accessed, the root password must first be configured.

About secure passwords

Important

Axis devices send the initially set password in clear text over the network. To protect your device after the first login, set up a secure and encrypted HTTPS connection and then change the password.

The device password is the primary protection for the data and services. Axis devices do not impose a password policy as they may be used in various types of installations. To protect your data we recommend that you:

- Change the default password that comes with the devices.
- Use a password with at least 8 characters, preferably created by a password generator.
- Don't expose the password.
- Change password at a recurring interval, at least once a year.

Set a secure password for the root account

Important

The default administrator user name **root** cannot be deleted. If the password for root is lost, the device must be reset to the factory default settings.

1. Make sure to follow the instructions about secure passwords. See *About secure passwords on page 7*.
2. Type a password and then retype it to confirm the spelling.
3. Click **Create login**. The password has now been configured.

AXIS Q87 Bispectral PTZ Network Camera Series

Setup

Setup

About the product's built-in help

You can access the built-in help through your product's webpage. The help provides more detailed information on the product's features and their settings.

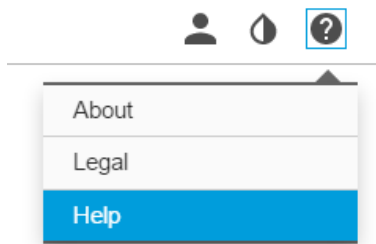

About events

The event pages allow you to configure your product to perform actions when different events occur. For example, the product can start a recording or send an email notification when motion is detected. The set of conditions that defines how and when the action is triggered is called an action rule.

How to trigger an action

1. Go to **Settings > System > Events** to set up an action rule. The action rule defines when the camera will perform certain actions. Action rules can be setup as scheduled, recurring, or for example, triggered by motion detection.
2. Select what **Trigger** must be met to trigger the action. If you specify more than one trigger for the action rule, all of them must be met to trigger the action.
3. Select which **Action** the camera should perform when the conditions are met.

Note

If you make changes to an active action rule, the action rule needs to be restarted for the changes to take effect.

How to use thermal camera motion detection to zoom in and record with the visual camera

In difficult lighting conditions the thermal camera can detect objects that the visual camera cannot. This example shows how to set up an event, using AXIS Video Motion Detection on the thermal camera, to zoom in and record with the visual camera.

Create a motion detection profile:

Note

Running VMD on both channels simultaneously may affect the frame rate and the general performance. For this example we recommend that you remove all VMD profiles on the visual camera.

1. Go to **Settings > Apps** and open **AXIS Video Motion Detection**.
2. Select **Thermal**.
3. Create a profile (call it for instance "gate profile") that covers the area of interest. Find out more in the User manual for **AXIS Video Motion Detection** on www.axis.com.

Create the preset positions:

4. Go to **Settings > PTZ > Preset positions**.

AXIS Q87 Bispectral PTZ Network Camera Series

Setup

Both channels share the same preset configurations.

5. Create the home position that includes the area of interest.
6. Create the zoomed-in preset position (call it for instance "gate position") so that it covers the area in the image where you predict that the moving object will appear.

Create the VMD event:

7. Go to **Settings > System > Events** and add an action rule.
8. Name the action rule *Gatekeeper*.
9. Set the trigger to:
 - **Applications**
 - **VMD 4: gate profile (Thermal)**
10. Set the action to:
 - **Type: PTZ Control**
 - **Control: Preset Position**
 - **Go to: gate position**
11. Select **Return to home position** when rule is no longer active.
12. Set the duration for the camera to stay in the gate position (wait at least 30 seconds before returning to home position).
13. Click **OK**.

Create the recording event:

14. Create an Action Rule and call it for example "record video".
15. Set the trigger to:
 - **PTZ**
 - **Preset Reached**
 - **Visual**
 - **gate position**
16. Set the action to:
 - **Type: Record Video**
 - **Select video source: Visual**
 - **Duration: While the rule is active**
 - **Storage: SD Card**
17. Click **Ok**.

How to set up the camera for daily cleaning of the visual window

The camera is often installed in inaccessible locations. This example explains how you can use the built-in wiper and optional washer to remove for instance sea salt, from the visual window without physically accessing it.

Configure the washer:

AXIS Q87 Bispectral PTZ Network Camera Series

Setup

1. Point the camera at the nozzle making sure that the nozzle is located in the center of the image.
2. Go to **Settings > System > Accessories**.
3. Turn on the **Nozzle position**.
4. Select the washer pump pin on which the washer is connected.

Create the action rule:

5. Go to **Settings > System > Events > Add**.
6. Create an Action Rule and call it for example "window wash".
7. Set the trigger to:
 - Time
 - Use Schedule
8. Click **New Schedule** and select:
 - Type: Daily
 - Start time: 12:00
 - End time: 12:01
 - Days: select all
9. Under **Actions** select -Type: **Washing Procedure**.
10. Click **OK**.

Image quality

How to hide parts of the image with privacy masks

Note

Privacy masks are only available for the visual camera.

What is a privacy mask?

A privacy mask is a user-defined area that prevents users from viewing a part of the monitored area. In the video stream, privacy masks appear as blocks of solid color.

You'll see the privacy mask on all snapshots, recorded video, and live streams.

You can use the VAPIX® application programming interface (API) to turn off the privacy masks.

Important

Using multiple privacy masks may affect the product's performance.

How to create a privacy mask

To create a privacy mask, go to **Settings > Privacy mask**.

How to reduce noise in low-light conditions

Note

Low-light settings are only available for the visual camera.

To reduce noise in low-light conditions, you can adjust one or more of the following settings:

- Make sure that the exposure mode is automatic.

AXIS Q87 Bispectral PTZ Network Camera Series

Setup

Note

Increasing the max shutter value can result in motion blur.

- The shutter speed should be as slow as possible, which means you should set max shutter to the highest possible value.

How to select exposure mode

Note

The exposure modes are only available for the visual camera.

There are different exposure mode options in the camera that adjusts aperture, shutter speed, and gain to improve image quality for specific surveillance scenes. Go to **Settings > Image > Exposure** and select between the following exposure modes:

- For most use cases, select **Automatic** exposure.
- For environments with certain artificial lighting, for example fluorescent lighting, select **Flicker-free**.
Select the same frequency as the power line frequency.
- For environments with certain artificial light and bright light, for example outdoors with fluorescent lighting at night and sun during daytime, select **Flicker-reduced**.
Select the same frequency as the power line frequency.

How to handle scenes with strong backlight

To make both dark and bright areas of the image visible, turn on WDR.

1. Go to **Settings > Image**.
2. Turn on WDR under **Wide dynamic range**.



Image without WDR.



Image with WDR.

AXIS Q87 Bispectral PTZ Network Camera Series

Setup

Note

If you use WDR, you may experience some WDR artifacts in the image.

Find out more about WDR and how to use it at axis.com/web-articles/wdr

PTZ (Pan Tilt Zoom)

How to limit pan, tilt, and zoom movements

In this example, the camera is surveilling a parking lot with nearby apartment buildings. Set pan, tilt and zoom limits to ensure privacy for residents.

To limit pan, tilt and zoom movements, go to **Settings > PTZ > Limits**.

About guard tours

A guard tour displays the video stream from different preset positions either in a predetermined or random order, and for configurable periods of time. Once started, a guard tour continues to run until stopped, even when there are no clients (web browsers) viewing the images.

How to create a guard tour with preset positions

1. Go to **Settings > PTZ > Guard tours**
2. Click **+**.
3. Select **Preset position**.
4. To edit the guard tour's properties, click 
5. Type a name for the guard tour and specify the pause length in minutes between each tour.
6. If you want the guard tour to go to the preset positions in a random order, turn on **Shuffle**.
7. Click **Done**.
8. Click **Add** to add the preset positions that you want in your guard tour.
9. Click **Done** to exit the guard tour settings.
10. To schedule the guard tour, go to **System > Events**.

Streaming and storage

How to choose video compression format

Decide which compression method to use based on your viewing requirements, and on the properties of your network. The available options are:

Motion JPEG

Motion JPEG or MJPEG is a digital video sequence that is made up of a series of individual JPEG images. These images are then displayed and updated at a rate sufficient to create a stream that shows constantly updated motion. For the viewer to perceive motion video the rate must be at least 16 image frames per second. Full motion video is perceived at 30 (NTSC) or 25 (PAL) frames per second.

The Motion JPEG stream uses considerable amounts of bandwidth, but provides excellent image quality and access to every image contained in the stream.

H.264 or MPEG-4 Part 10/AVC

AXIS Q87 Bispectral PTZ Network Camera Series

Setup

Note

H.264 is a licensed technology. The Axis product includes one H.264 viewing client license. Installing additional unlicensed copies of the client is prohibited. To purchase additional licenses, contact your Axis reseller.

H.264 can, without compromising image quality, reduce the size of a digital video file by more than 80% compared to the Motion JPEG format and by as much as 50% compared to the MPEG-4 standard. This means that less network bandwidth and storage space are required for a video file. Or seen another way, higher video quality can be achieved for a given bitrate.

How to reduce bandwidth and storage

Important

If you reduce the bandwidth it can result in loss of details in the picture.

1. Go to live view and select H.264.
2. Go to **Settings > Stream**.
3. Do one or more of the following:
 - Turn on the Zipstream functionality and select the desired level.
 - Turn on dynamic GOP and set a high GOP length value.
 - Increase the compression.
 - Turn on dynamic FPS.

How to set up network storage

To store recordings on the network, you need to set up network storage:

1. Go to **Settings > System > Storage**.
2. Click **Setup** under **Network storage**.
3. Enter the IP address of the host server.
4. Enter the name of the shared location on the host server.
5. Move the switch if the share requires a login, and enter username and password.
6. Click **Connect**.

About applications

AXIS Camera Application Platform (ACAP) is an open platform that enables third parties to develop analytics and other applications for Axis products. To find out more about available applications, downloads, trials and licenses, go to axis.com/applications

To find the user manuals for Axis applications, go to axis.com

Note

- Several applications can run at the same time but some applications might not be compatible with each other. Certain combinations of applications might require too much processing power or memory resources when run in parallel. Verify that the applications work together before deployment.

Install an SD card (pre-mounted)

A standard or high capacity SD card can be used to store recordings locally in the product. See *SD card slot* on page 19 before installing the SD card.

AXIS Q87 Bispectral PTZ Network Camera Series

Setup

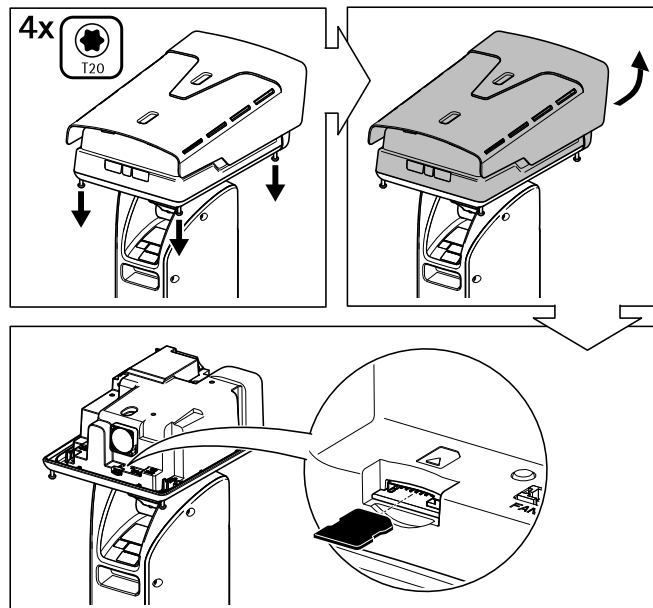

1. Disconnect power from the product.
2. Unscrew the four top cover screws and remove the top cover.
3. Insert an SD card into the SD card slot, see *Connectors on page 19*.
4. Replace the top cover and tighten the screws (torque 2.0 Nm).
5. Re-connect power to the product.

AXIS Q87 Bispectral PTZ Network Camera Series

Troubleshooting

Troubleshooting

Reset to factory default settings

CAUTION

 Risk of injury. Moving parts. Keep your body parts away from the product when in operation. Disconnect from power supply before installing or performing maintenance on the product.

CAUTION

 Risk of injury. Hot surface. Do not touch the product when in operation. Disconnect from power supply and allow the surfaces to cool before performing maintenance on the product.

NOTICE

Removing the top cover exposes parts of the visual camera that are sensitive to impact. Avoid hitting the unprotected camera with the top cover at disassembly.

Important

Reset to factory default should be used with caution. A reset to factory default will reset all settings, including the IP address, to the factory default values.

Note

The installation and management software tools are available from the support pages on www.axis.com/support/downloads

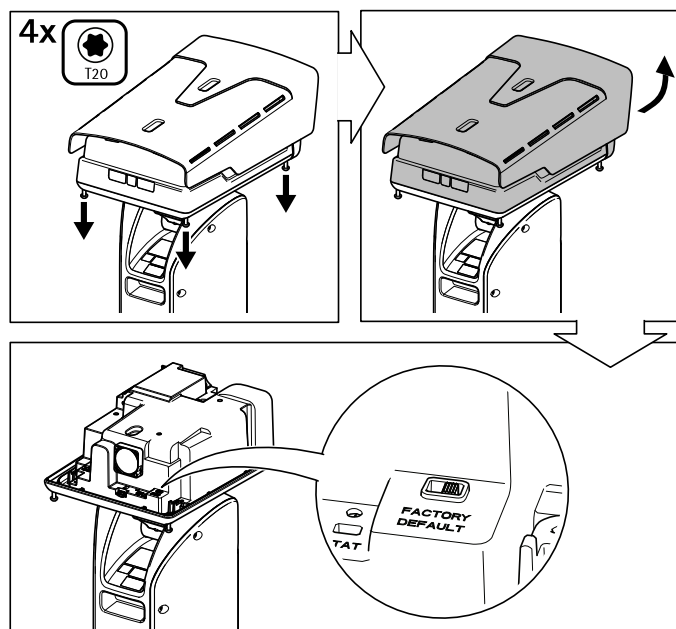

1. Disconnect power from the product.
2. Loosen the four top cover screws and remove the top cover.
3. Change the position of the Factory default switch.
4. Replace the top cover and tighten the screws (torque 2.0 Nm).

AXIS Q87 Bispectral PTZ Network Camera Series

Troubleshooting

5. Reconnect power to the product.

You can also reset parameters to factory default through the product's webpages. Go to **Settings > System > Maintenance** and click **Default**.

How to check the current firmware

Firmware is the software that determines the functionality of network devices. One of your first actions when troubleshooting a problem should be to check the current firmware version. The latest version may contain a correction that fixes your particular problem.

To check the current firmware:

1. Go to the product's webpage.
2. Click on the help menu. 
3. Click **About**.

How to upgrade the firmware

Important

Preconfigured and customized settings are saved when the firmware is upgraded (provided that the features are available in the new firmware) although this is not guaranteed by Axis Communications AB.

Important

Make sure the product remains connected to the power source throughout the upgrade process.

Note

When you upgrade the product with the latest firmware, the product receives the latest functionality available. Always read the upgrade instructions and release notes available with each new release before upgrading the firmware. To find the latest firmware and the release notes, go to axis.com/support/firmware

1. Download the latest firmware file to your computer, available free of charge at axis.com/support/firmware
2. Log in to the product as an administrator.
3. Go to **Settings > System > Maintenance** in the product's webpage and follow the instructions. When the upgrade has finished, the product restarts automatically.

Technical issues, clues and solutions

If you can't find what you're looking for here, try the troubleshooting section at axis.com/support

Problems upgrading the firmware

Firmware upgrade failure	If the firmware upgrade fails, the product reloads the previous firmware. The most common reason is that the wrong firmware file has been uploaded. Check that the name of the firmware file corresponds to your product and try again.
--------------------------	---

AXIS Q87 Bispectral PTZ Network Camera Series

Troubleshooting

Problems setting the IP address

The product is located on a different subnet	If the IP address intended for the product and the IP address of the computer used to access the product are located on different subnets, you cannot set the IP address. Contact your network administrator to obtain an IP address.
The IP address is being used by another device	<p>Disconnect the Axis product from the network. Run the ping command (in a Command/DOS window, type <code>ping</code> and the IP address of the product):</p> <ul style="list-style-type: none"> If you receive: <code>Reply from <IP address>: bytes=32; time=10...</code> this means that the IP address may already be in use by another device on the network. Obtain a new IP address from the network administrator and reinstall the product. If you receive: <code>Request timed out</code>, this means that the IP address is available for use with the Axis product. Check all cabling and reinstall the product.
Possible IP address conflict with another device on the same subnet	The static IP address in the Axis product is used before the DHCP server sets a dynamic address. This means that if the same default static IP address is also used by another device, there may be problems accessing the product.

The product cannot be accessed from a browser

Cannot log in	<p>When HTTPS is enabled, ensure that the correct protocol (HTTP or HTTPS) is used when attempting to log in. You may need to manually type <code>http</code> or <code>https</code> in the browser's address field.</p> <p>If the password for the user <code>root</code> is lost, the product must be reset to the factory default settings. See <i>Reset to factory default settings</i> on page 15.</p>
The IP address has been changed by DHCP	

The product is accessible locally but not externally

Router configuration	Check that your router allows incoming data traffic to the Axis product. The router must support UPnP®.
Firewall protection	Check the Internet firewall with your network administrator.

Performance considerations

When setting up your system, it is important to consider how various settings and situations affect the performance. Some factors affect the amount of bandwidth (the bitrate) required, others can affect the frame rate, and some affect both. If the load on the CPU reaches its maximum, this also affects the frame rate.

The following factors are the most important to consider:

- High image resolution or lower compression levels result in images containing more data which in turn affects the bandwidth.
 - Access by large numbers of Motion JPEG or unicast H.264 clients affects the bandwidth.
 - Simultaneous viewing of different streams (resolution, compression) by different clients affects both frame rate and bandwidth.
- Use identical streams wherever possible to maintain a high frame rate. Stream profiles can be used to ensure that streams are identical.
- Accessing Motion JPEG and H.264 video streams simultaneously affects both frame rate and bandwidth.
 - Heavy usage of event settings affects the product's CPU load which in turn affects the frame rate.
 - Using HTTPS may reduce frame rate, in particular if streaming Motion JPEG.
 - Heavy network utilization due to poor infrastructure affects the bandwidth.

AXIS Q87 Bispectral PTZ Network Camera Series

Troubleshooting

- Viewing on poorly performing client computers lowers perceived performance and affects frame rate.
- Running multiple AXIS Camera Application Platform (ACAP) applications simultaneously may affect the frame rate and the general performance.
- Running multiple AXIS Camera Application Platform (ACAP) applications on the Visual and Thermal channels simultaneously may affect the frame rate and the general performance.

AXIS Q87 Bispectral PTZ Network Camera Series

Specifications

Specifications

To find the latest version of the product's datasheet, go to the product page on axis.com and locate **Support & Documentation**.

SD card slot

NOTICE

- Risk of damage to SD card. Do not use sharp tools, metal objects or excessive force when inserting or removing the SD card. Use your fingers to insert and remove the card.
- Risk of data loss and corrupted recordings. Do not remove the SD card while the product is running. Disconnect power before removal.

For SD card recommendations, see www.axis.com

Connectors

Network connector

RJ45 Ethernet connector.

SFP connector.

I/O connector

Use the I/O connector with external devices in combination with, for example, motion detection, event triggering, and alarm notifications. In addition to the 0 V DC reference point and power (DC output), the I/O connector provides the interface to:

Digital input – For connecting devices that can toggle between an open and closed circuit, for example PIR sensors, door/window contacts, and glass break detectors.

Digital output – For connecting external devices such as relays and LEDs. Connected devices can be activated by the VAPIX® Application Programming Interface or in the product's webpage.

6-pin configurable terminal block

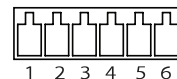

Example

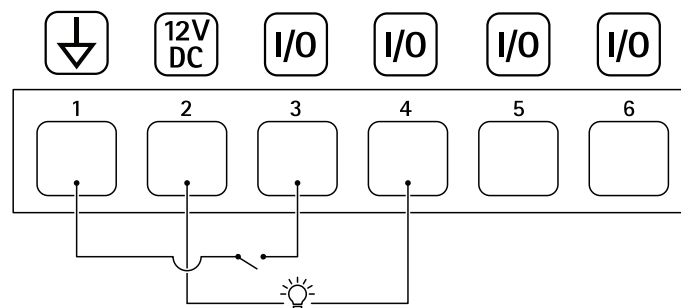

- 1 DC ground
- 2 DC output 12 V, max 50 mA
- 3 I/O configured as input
- 4 I/O configured as output

AXIS Q87 Bispectral PTZ Network Camera Series

Specifications

- 5 Configurable I/O
- 6 Configurable I/O

Power connector

4-pin terminal block for power input.

24 V AC/DC power connector

NOTICE

This section is valid for products powered by 24 V AC and 24 V DC only.

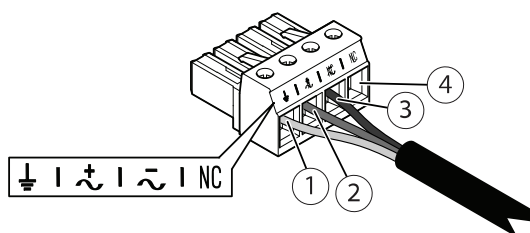

This table is only valid for the 24 V AC and the 24 V DC power connectors.

Position	24 V AC	24 V DC
1	Protective earth	Protective earth
2	24 V AC Phase	+ 24 V
3	24 V AC Neutral	0 V
4	Not connected	Not connected

Illuminator connectors

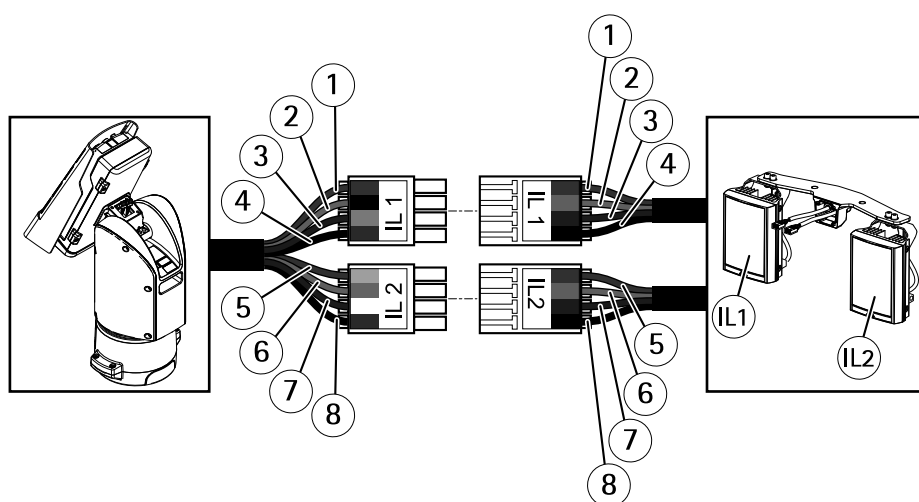

AXIS Q87 Bispectral PTZ Network Camera Series

Specifications

	Position	Cable color (positioning unit)	Cable color (illuminators)	Description
IL1	1	Red	Red	+24V IL
	2	Black	Orange	IL1 +VE
	3	Gray	Purple	IL1 -VE
	4	Blue	Black	GND
IL2	5	Yellow	Red	+24V IL
	6	Orange	Orange	IL2 +VE
	7	White	Purple	IL2 -VE
	8	Green	Black	GND

